

SADIE SCALLOP COT

INSTRUCTIONS

PRODUCT CODE: 57158

COUNTRY OF ORIGIN: Vietnam

COMPOSITION: EU Ash & Plywood.

IMPORTANT: PLEASE READ THE INSTRUCTIONS CAREFULLY
AND KEEP FOR FUTURE REFERENCE.

FOR ASSEMBLY:

- Check all contents are included and no pieces are missing or broken.
- It is recommended assembly is done on a soft surface to avoid damage.
 - During assembly do not overtighten screws and fitting.
- Once assembly is complete ensure all screws and fitting are tight and firm.
 - Mattress is not included.

ADAIRS RETAIL GROUP

2 International Court Caribbean Business Park,
Scoresby Vic 3179 | 03 8888 4500



adairs kids

adairs kids

SADIE SCALLOP COT

AUSTRALIA AND NEW ZEALAND (AS/NZS 2172:2013)

RECOMMENDED MATTRESS SIZE 1300mm x 690mm x 130mm

This cot has been manufactured for use with a mattress which measures 690mm wide by 1300mm long and 130mm in thickness. The width and length are specified because it is important that the gaps between the mattress and the sides and ends of the cot will not exceed 40mm when the mattress is pushed to one side or end, and 20mm when the mattress is centred in the cot. This is to minimise the risk of a child's limb becoming caught in the gap. The thickness of the mattress has been specified to ensure that the depth of the cot is greater than 500mm with the mattress base in the lower position to minimise the risk of a child climbing or falling out of the cot.

- Follow the manufacturer's assembly instructions in detail to ensure the safety features of the cot are not compromised.
- Ensure the cot is placed at a reasonable distance from curtains, blinds, heaters and power points. *Keep cot free of any toys, cushions etc that could be used as a foothold or present a danger of suffocation or strangulation.
- Keep medication, String, elastic or small items such as money out of reach from any position in the cot.

CARE INSTRUCTIONS:

- Clean furniture by lightly wiping the surface with a soft dampened cloth.
- Do not use strong house hold cleaners and avoid using hot liquids.
- Avoid contact with sharp edges or objects.
- Do not expose furniture to strong sunlight, direct heat sources, extreme changes in temperature or moisture.
- When moving the furniture, lift into piece do not drag.

*If you are experiencing a problem with this product please contact the Adairs Retail Group via the following available methods.

☎ 1300 783 005

✉ info@adairs.com.au

🌐 adairs.com.au/adairs.co.nz

WARNING: TO ENSURE THE SAFETY OF YOUR COT, REGULARLY CHECK ALL THE CONNECTING BOLTS MAKING SURE THEY ARE TIGHT.

WARNING: TO PREVENT FALLS OR SUFFOCATION THE MAXIMUM MATTRESS THICKNESS SHOULD NOT EXCEED 130MM.

WARNING: TO PREVENT FALLS, THE MATTRESS BASE OF THIS COT SHOULD BE ADJUSTED TO THE LOWEST POSITION BEFORE THE CHILD CAN SIT UP.

ASSEMBLY INSTRUCTIONS

SADIE SCALLOP COT

adairs kids

Please read instructions carefully. Remove all wrapping material, staples and packing straps from the carton. See Hardware and Furniture Parts List for guidance. Be sure you have all parts before you start assembling. Place all wooden furniture parts on a clean and flat soft surface, such as carpet or rug to prevent from being scratched.

PARTS INCLUDED

- 1. Side Frame : 2pcs
- 2. End Frame : 2pcs
- 3. Mattress Base : 1pc

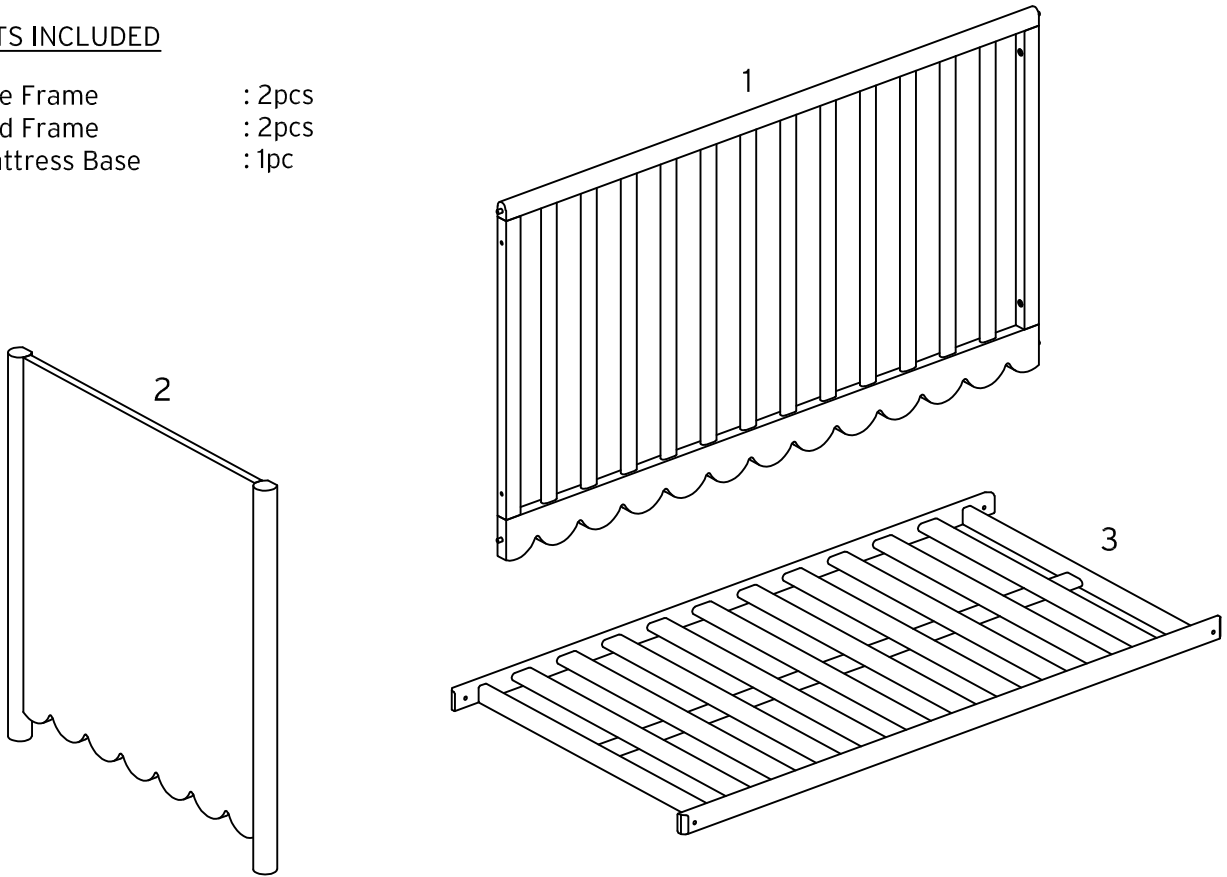

HARDWARE LIST

⚠ WARNING:
This package contains small parts.
Keep away from children until assembled.

- A. Long Bolt : 8pcs
- B. Medium Bolt : 4pcs
- C. Short Bolt : 4pcs
- D. Washer : 12pcs
- E. Allen Key : 1pc

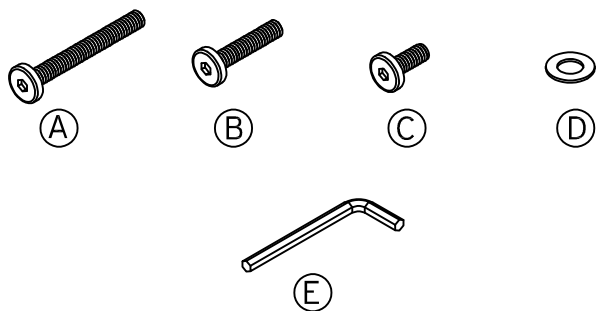

ASSEMBLY INSTRUCTIONS

SADIE SCALLOP COT

adairs kids

Upper Position

STEP 1

Lay down one of the side frames (1), connect to the two end frame (2) with 4 connecting long bolts (A) and washers (D) to barrel holes.

Note : Do not tighten bolts at this stage.

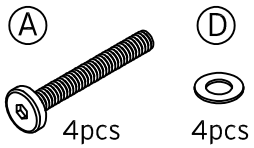
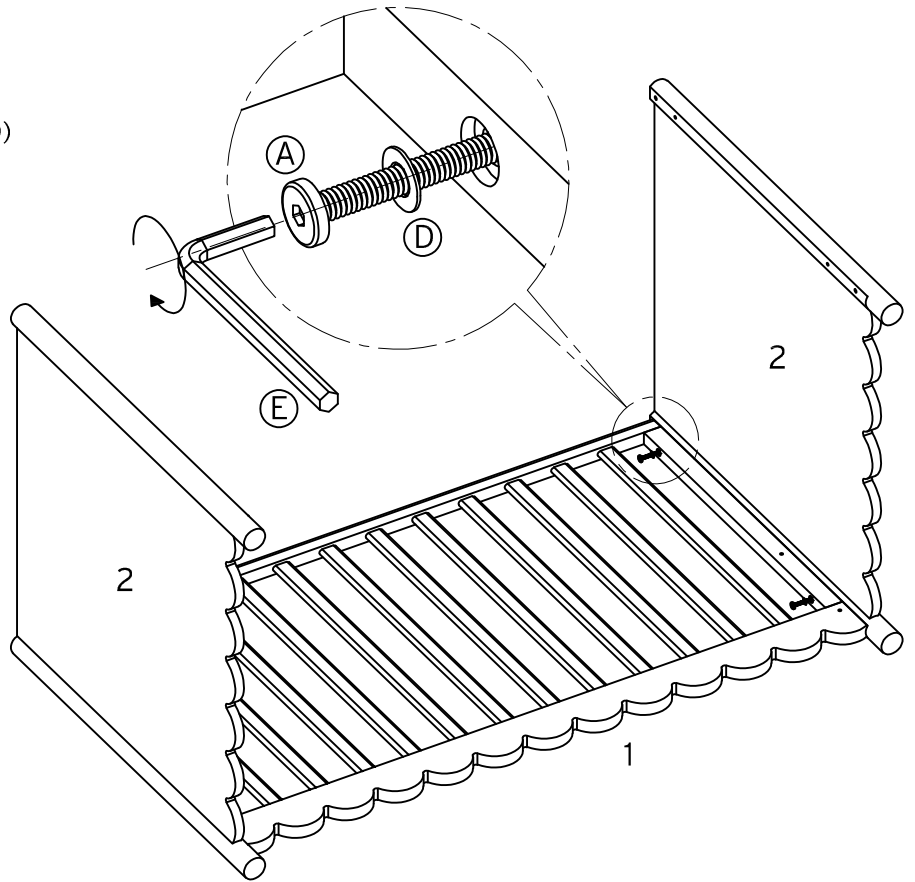

STEP 2

Connect the mattress base (3) in correct orientation as "This side up" indicated on frame to the side frame with 2 connecting bolts (B) and washers (D) at upper position.

Note : Do not tighten bolts at this stage.

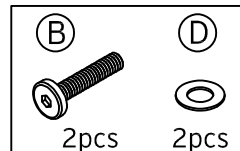
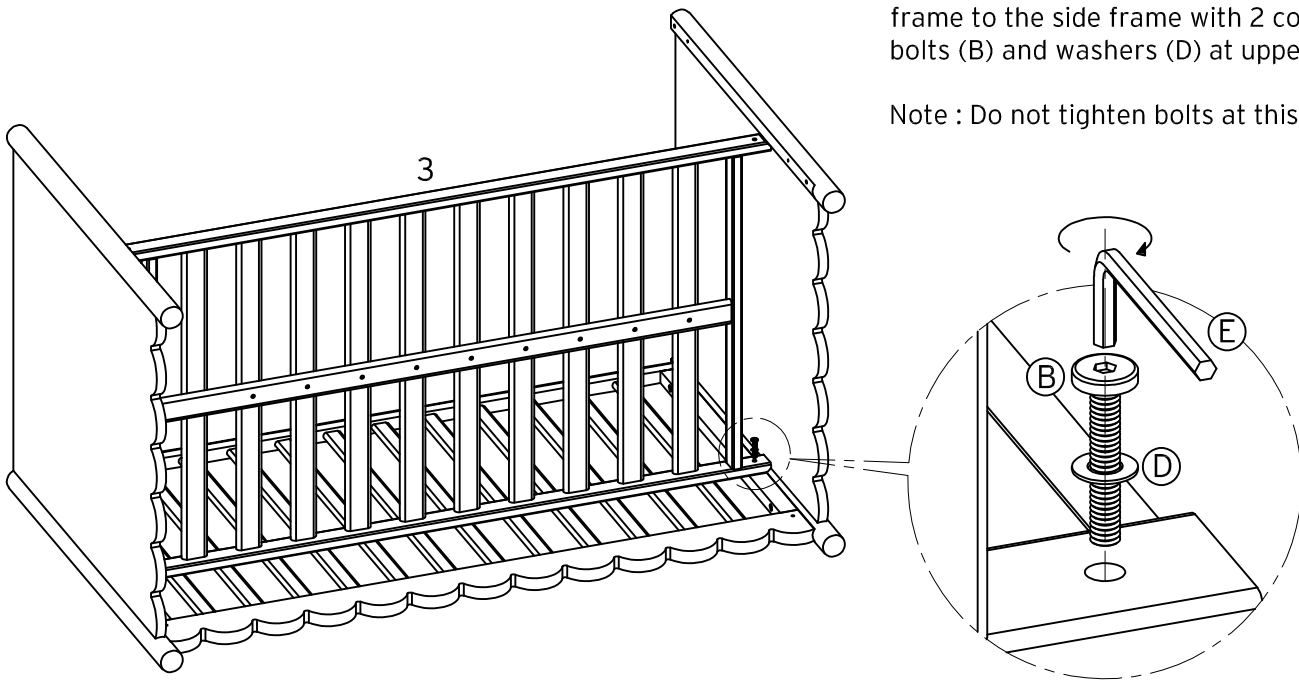

ASSEMBLY INSTRUCTIONS

SADIE SCALLOP COT

adairs kids

Upper Position

STEP 3

Connect the other side frame (1) to the two end frame with 4 connecting bolts (A) and washers (D) to barrel holes.

Connect the mattress base (3) to the side frame (1) with 2 connecting bolts (B) and washers (D) to barrel holes.

Note : Tighten all the bolts at this stage.

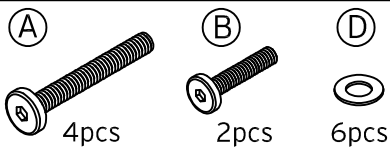
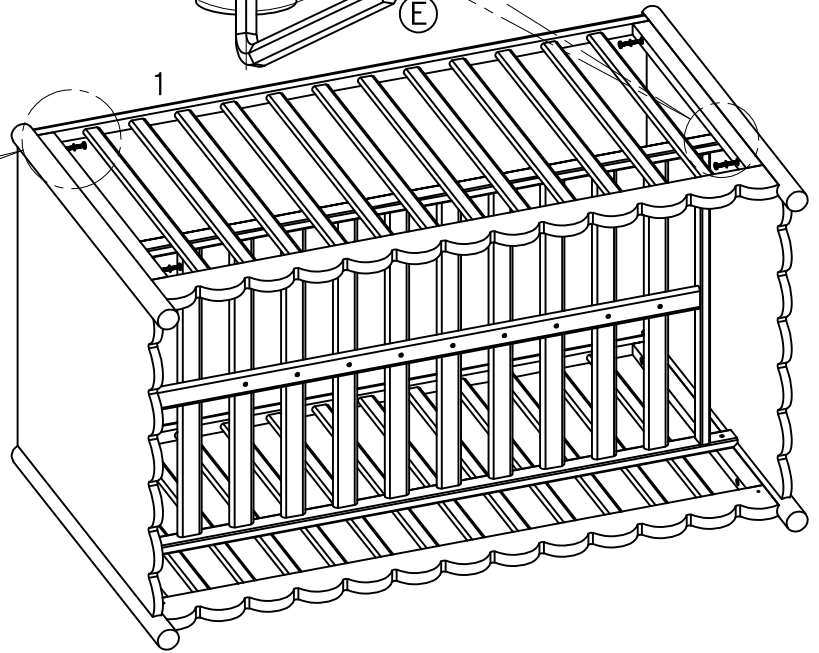
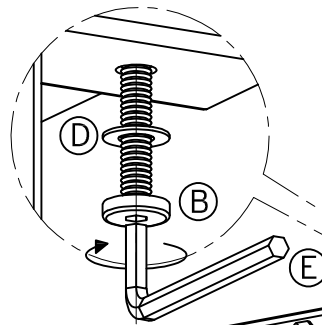
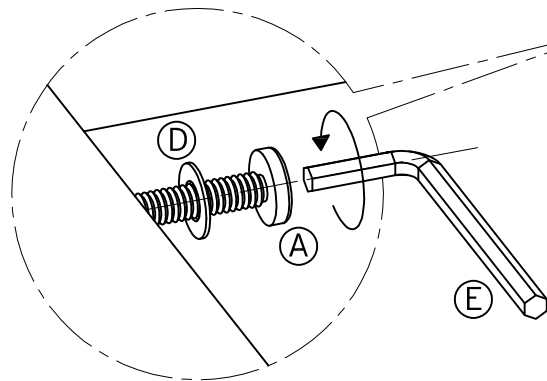

STEP 4

Fill in used position holes on the side frames with 4 connecting bolts (C).

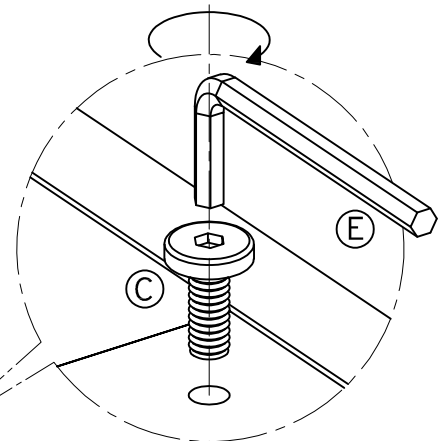
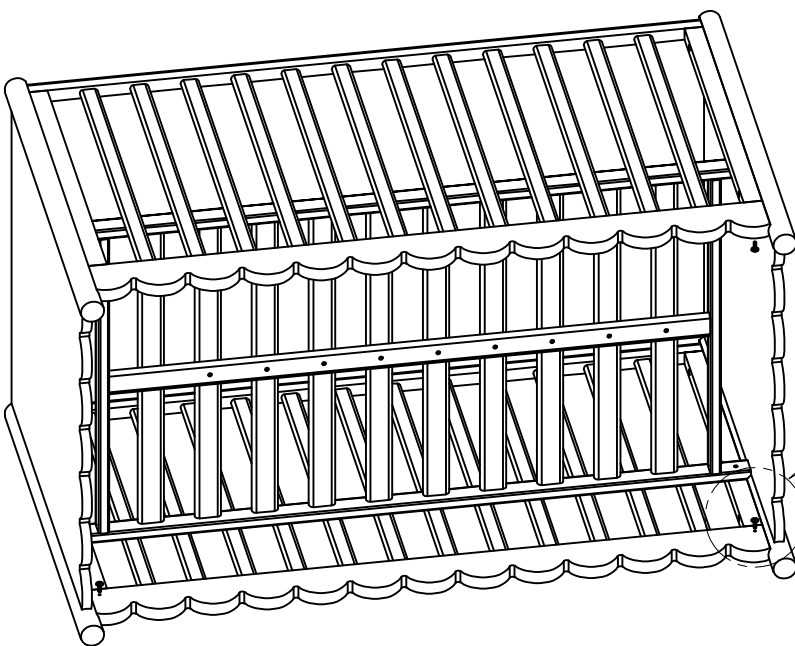

www.adairs.com.au
www.adairs.co.nz

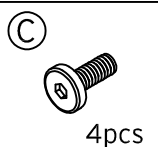

ASSEMBLY INSTRUCTIONS

SADIE SCALLOP COT

adairs kids

Lower Position

STEP 1

Lay down the cot. Remove 4 connecting bolts (C) from bottom holes.

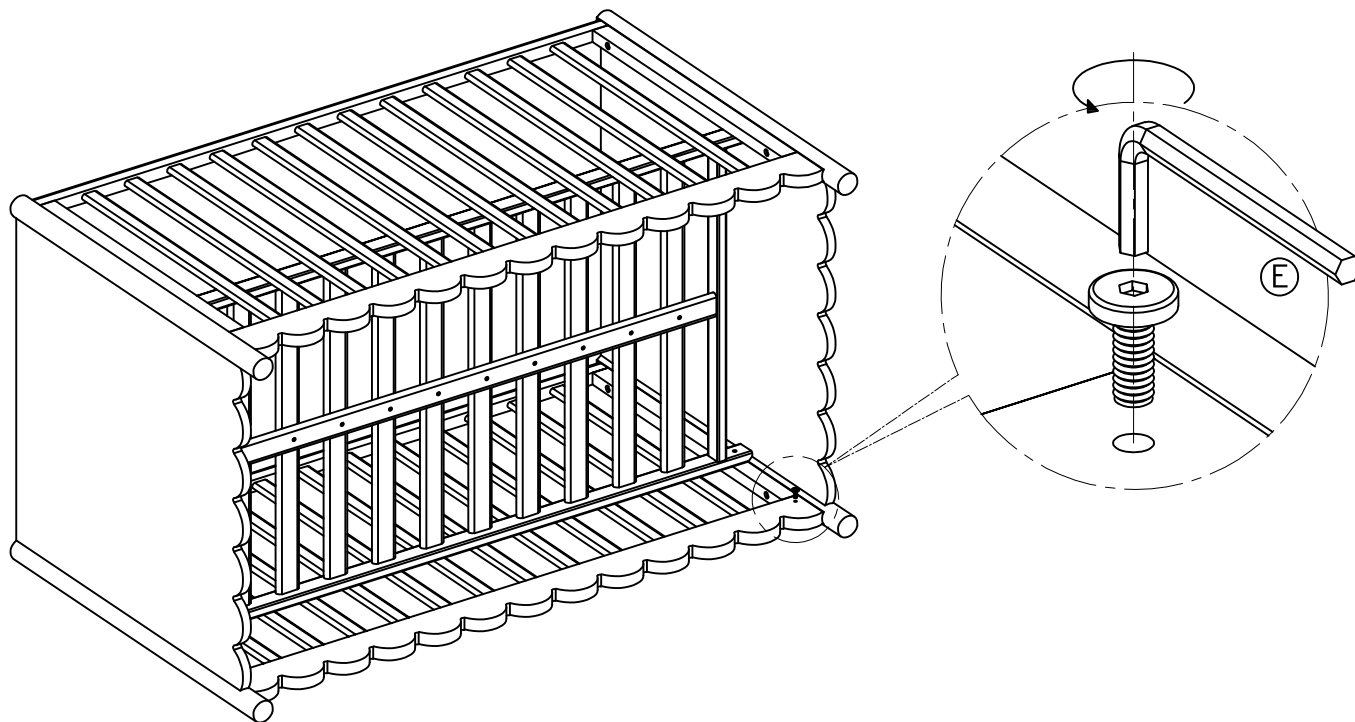

STEP 2

Unscrew 4 connecting bolts (A) and washers (D) to remove mattress base (3) to lower position.

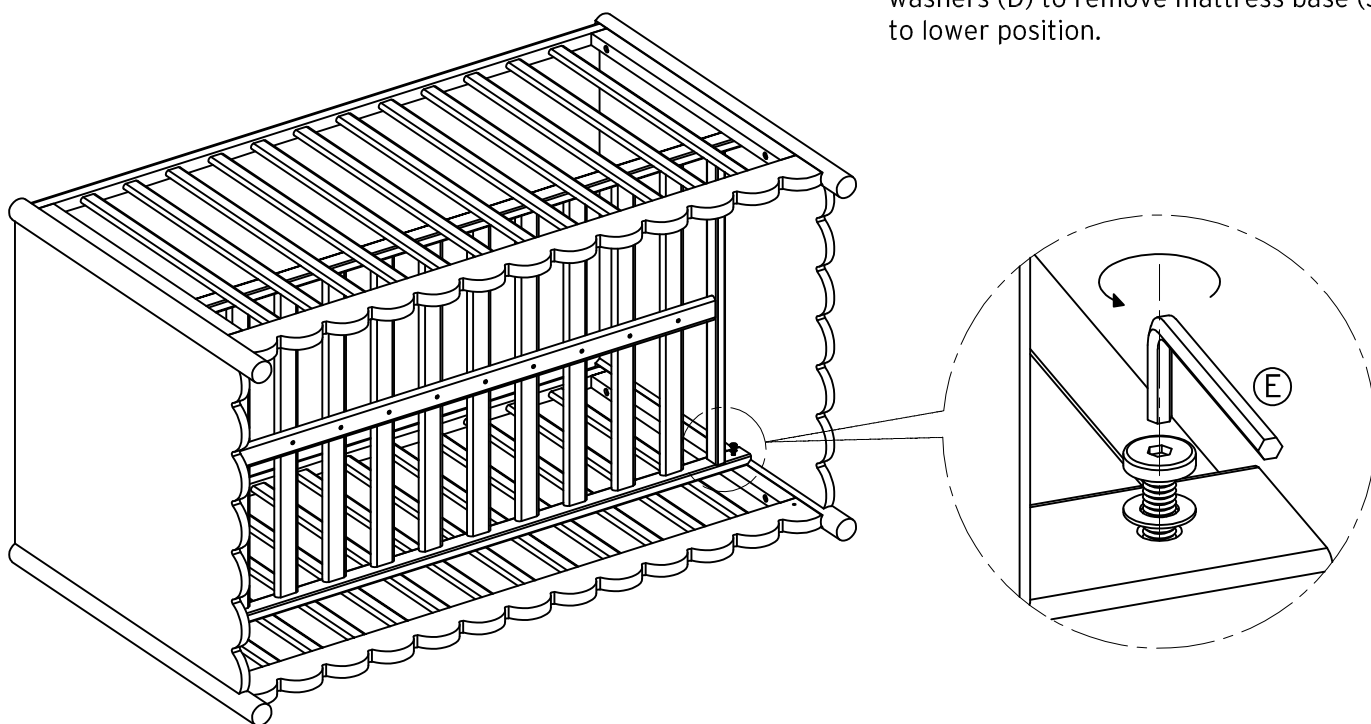

ASSEMBLY INSTRUCTIONS

SADIE SCALLOP COT

adairs kids

Lower Position

STEP 3

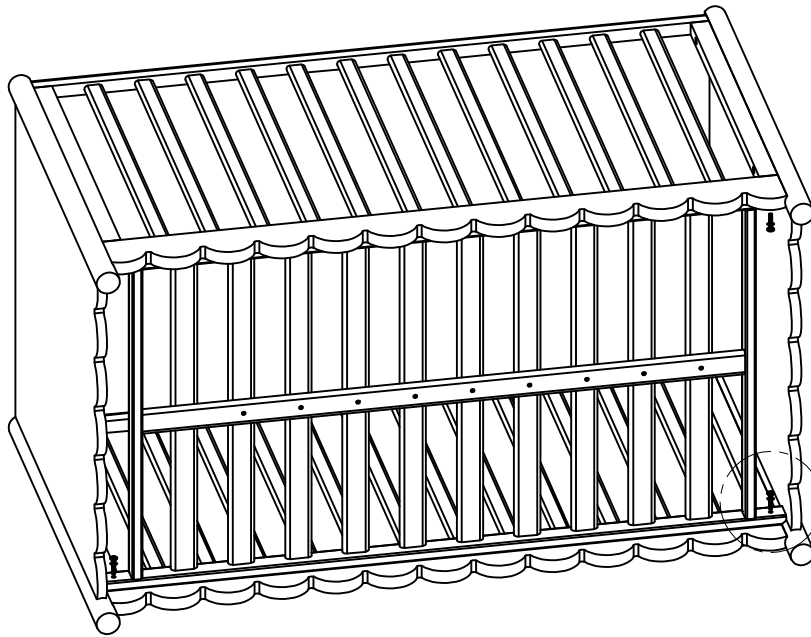

Adjust the mattress base (3) position and connect to two side frame (2) with 4 connecting bolts (B) and washers (D) to bottom holes.

Note : Tighten all the bolts at this stage.

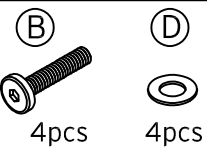
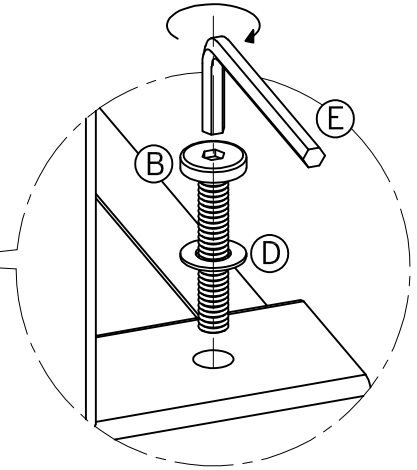

STEP 4

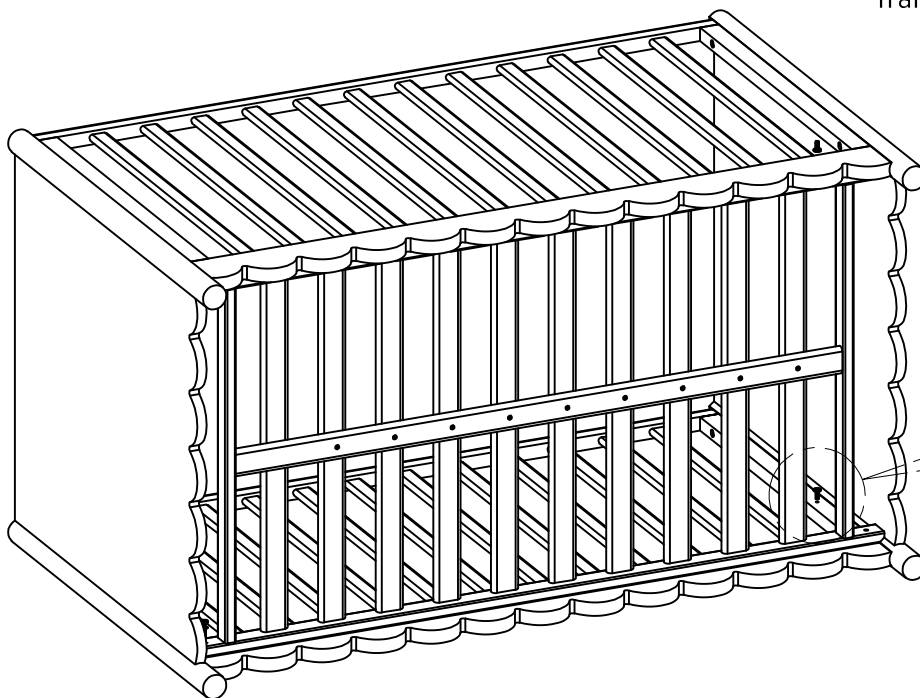

Block the unused position holes on the side frame with 4 connecting bolts (C).

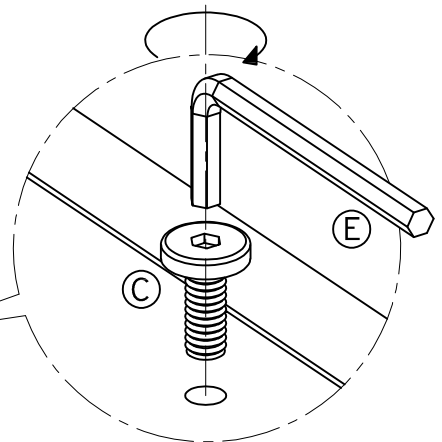

www.adairs.com.au
www.adairs.co.nz

