

ASSEMBLY INSTRUCTIONS

CLINTON DESK CHAIR

Please read instructions carefully. Remove all wrapping material, staples and packing straps from the carton. See Hardware and Furniture Parts List for guidance. Be sure you have all parts before you start assembling. Place all wooden furniture parts on a clean and flat soft surface, such as carpet or rug to prevent from being scratched.

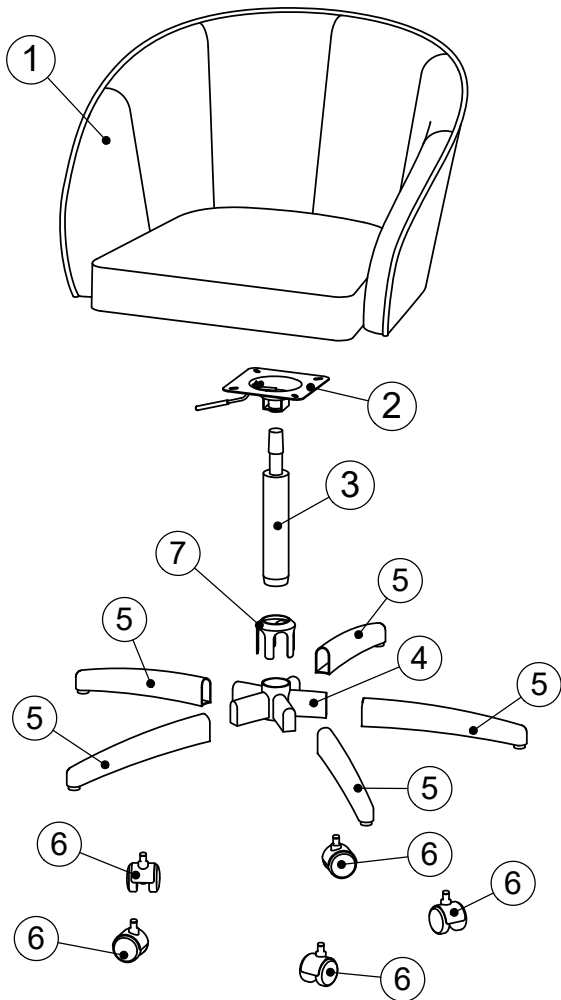

PARTS INCLUDED

1. SEAT	:1PC
2. METAL PLATE	:1PC
3. GAS LIFT	:1PC
4. STAR BASE	:1PC
5. LEG	:5PCS
6. CASTOR	:5PCS
7. DECOR CAP	:1PC

HARDWARE LIST

A. BOLT	:5PCS
B. FLAT WASHER	:9PCS
C. SPRING WASHER	:5PCS
D. BOLT	:4PCS
E. ALLEN KEY	:1PC

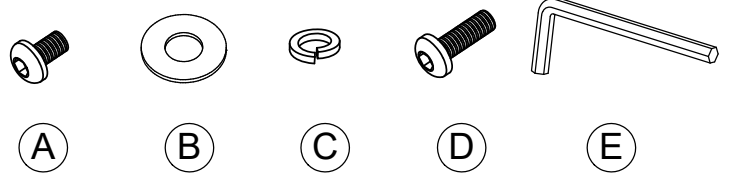

FOR ASSEMBLY

- First, check the content to make sure that nothing is missing.
- Sort out the parts and fittings as shown, assemble product step by step.
- It is preferable to rest the product on a soft surface to avoid damage during assembly.
- Do not over tighten screws and fittings.
- Re-tighten all screws and fittings periodically.

ATTENTION:

Regularly check chair feet are in correct positioning to sit flat on floor surface, this helps prevent damage to flooring.

ASSEMBLY INSTRUCTIONS

CLINTON DESK CHAIR

STEP 1

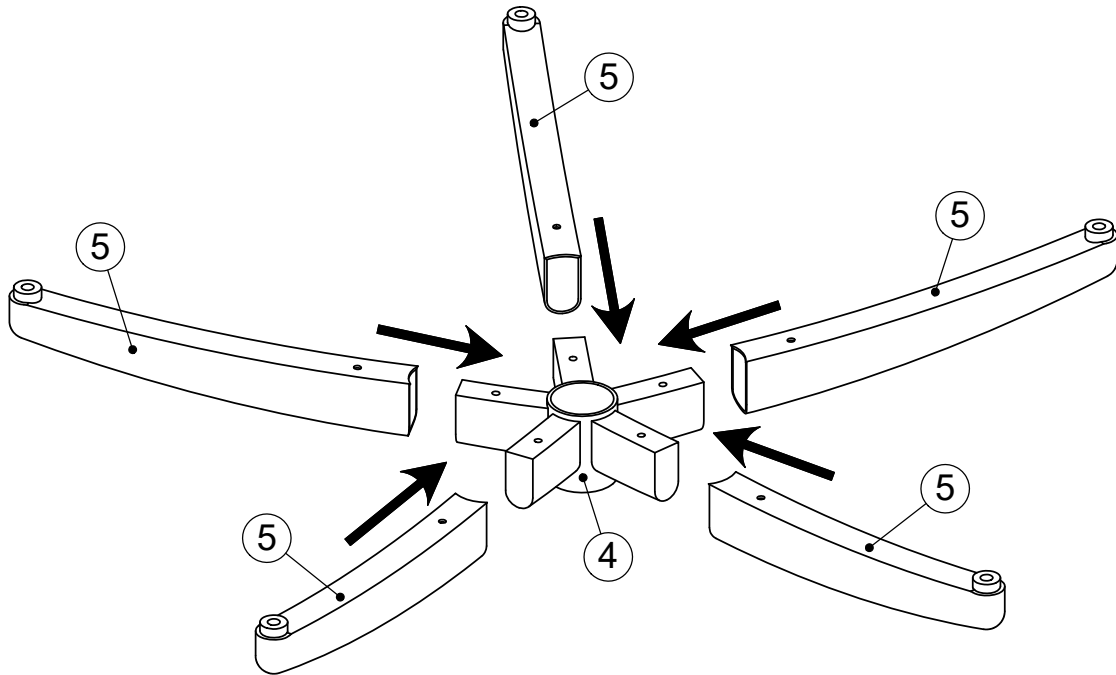

STEP 2

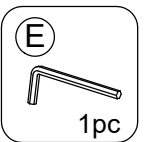
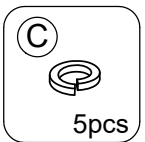
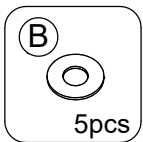
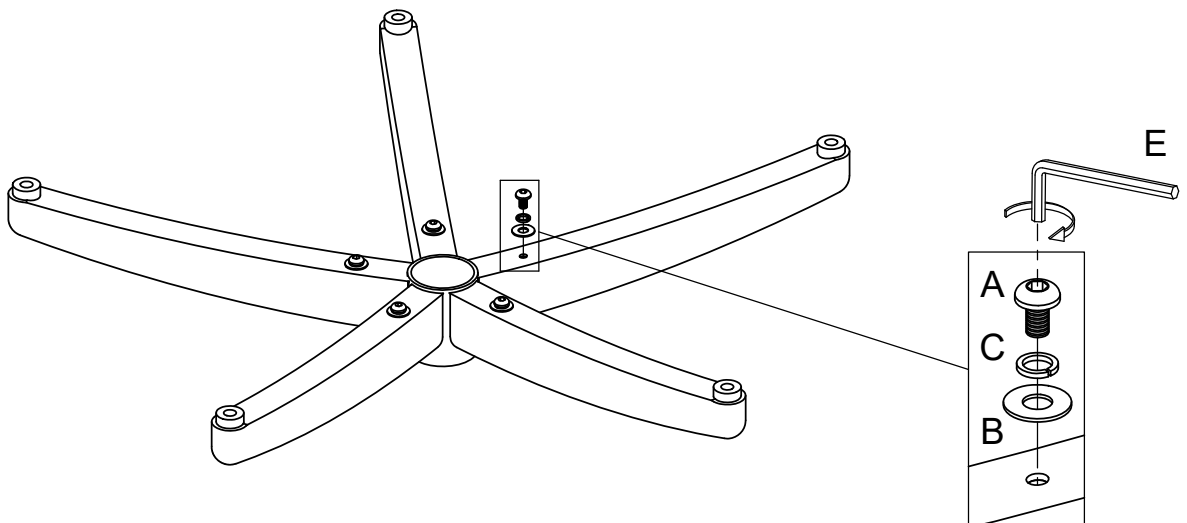

ASSEMBLY INSTRUCTIONS

CLINTON DESK CHAIR

STEP 3



Please remove
before assembly!

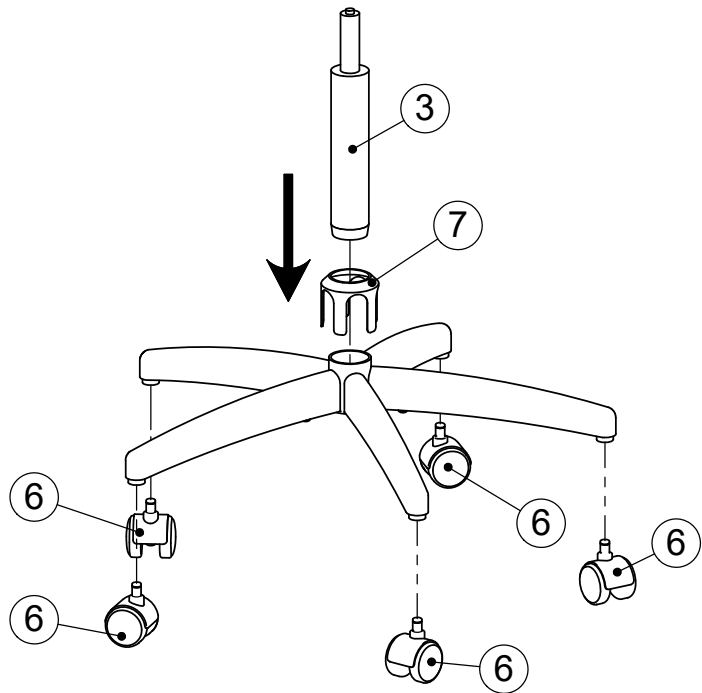
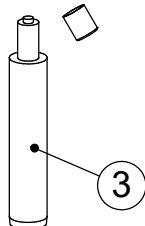
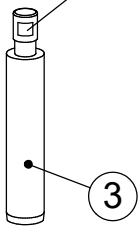

STEP 4

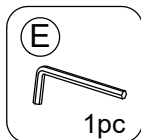
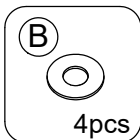
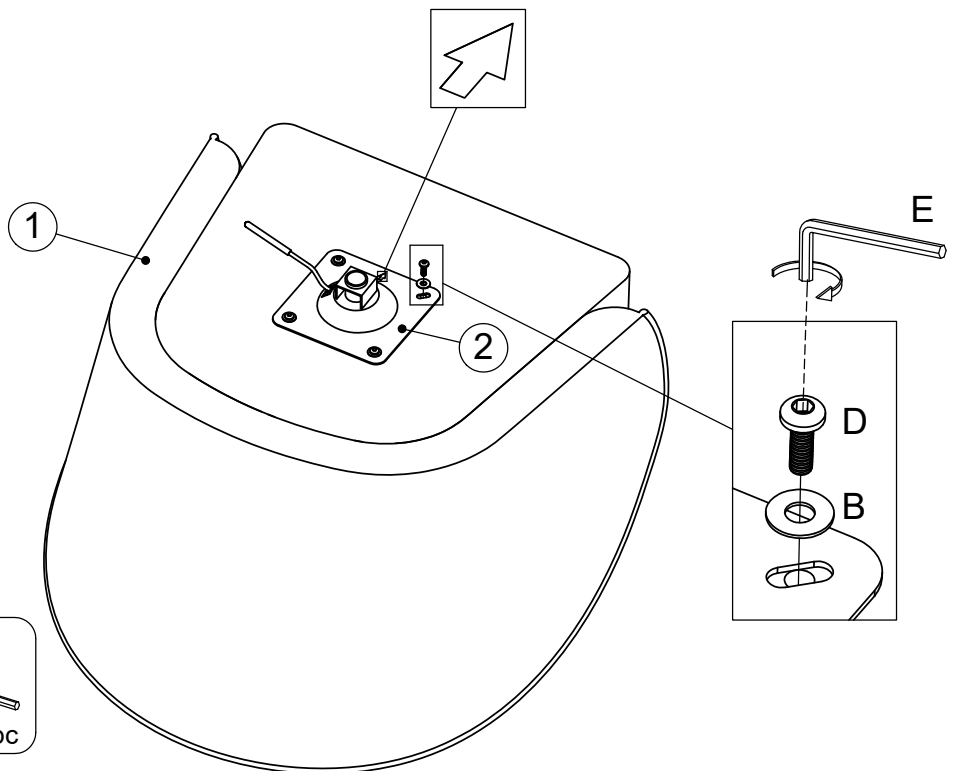

ASSEMBLY INSTRUCTIONS CLINTON DESK CHAIR

STEP 5

